

## Fully Automatic Type Z Purge & Pressurization System for Zone 2 Gas Applications



### Performance & Flexibility

- Purges enclosures up to 6.1m<sup>3</sup> (ATEX/IECEX 5 volume changes)
- Automatic leakage compensation, eliminates time consuming flow rate adjustment, and addresses increased enclosure leakage over time. Minimises consumption of purge gas
- ATEX, IECEX, UKEX certified

### Simple installation

- All-in-one unit contains the purge gas inlet, overpressure relief valve and control system – eliminates the need to install and connect multiple components.
- Simplest configuration – setting the purge timer is the only user input.

### What is it?

The SmartPurge Z is a fully certified purge and pressurization system for Zone 2 hazardous area applications. When fitted to a suitable enclosure, the system enables standard uncertified electrical equipment to be operated safely in a hazardous location.

The SmartPurge Z uniquely contains all elements of a purge and pressurization system; control unit, purge inlet and purge outlet with an overpressure relief valve, in a single robust GRP housing. Additionally, the system provides automatic switching between purge modes and control of leakage compensation flow rate.

Simple to install and configure, and able to purge a wide range of enclosure sizes, SmartPurge Z is ideally suited for use with OEM systems, gas analysers, DCS systems, and other electrical enclosures.

### How does it work?

When purge is started the system supplies a high flow of purge gas, usually compressed air, and monitors that flow at the outlet valve. Providing that flow is sufficient, the purge timer is started. The purge timing is simple to set during commissioning of the unit. Purging in progress is indicated by flashing green LEDs.

After the purge time is complete, the purge gas flow stops and the system switches to Leakage Compensation mode, controlling a lower flow of purge gas, sufficient to compensate for any enclosure leakage. This flow rate is automatically adjusted in real time to compensate for enclosure leakage, including any change in enclosure integrity. This pressurized mode is indicated by solid green LEDs.

The enclosure pressure is continually monitored. Any fall below the low pressure alarm level is indicated by red LEDs. Contacts are included to permit connection to a remote alarm system.

### Typical Applications

- Control panel purge
- Process gas analysers
- DCS systems
- Label printers; PCs; monitors



Simplifying Complexity. Delivering Safety.

 expo  
Technologies

## Specifications

Hazardous environment	Zone 2
Ambient temperature range	Certified for use from -20°C to +58°C (-4°F to +136°F).
Hazardous area approvals	IECEX; ATEX; UKEX
Purging mode	Automatic Leakage Compensation
Purge gas supply unit	Integrated solenoid valve. 4.0–5.0 bar instrument air supply (or other inert gas). Must be regulated at inlet.
Purge flow rate	Minimum 310 NI/min (1.1 SCFM) at 4 bar (58psi) supply pressure. Leakage compensation capacity; up to 90 NI/min (3.2 SCFM)
Purge time	User selectable 1-99 mins
Enclosure size	Suitable for enclosures up to 6.1 m <sup>3</sup> (ATEX/IECEX 5 volume changes)
Enclosure pressure	Nominally 2.0–4.5 mbar (0.8–1.8"wc) after purge phase
Low pressure alarm	Fixed at 0.5 mbar (0.2"wc)
Relief valve	Integrated into the unit. Lift-Off pressure: 10 mbar (4"wc).
Status indication	LED: Green flashing –purge in progress; Green solid-enclosure pressurized; Red- Alarm
Purge flow measurement	Direct purge flow measurement at relief valve exhaust to ensure full code compliance
Signal outputs	Low pressure alarm: N.O. volt-free dry contact. Rating AC-1 250VAC, 8A; DC-1 30VDC, 6A.
Power requirements	AC model 90–254 VAC, 50-60 Hz. Nominal 65mA @ 230VAC. Nominal 125mA @ 110VAC DC model: 18-30 VDC. Nominal 300mA @ 24VDC
Material/Ingress protection	Housing GRP. Maintains IP66.
Product weight	3kg (6.6lb)
Installation	Direct mount to the purged enclosure wall. Single purge gas pipe to run to opposite corner of enclosure (3m / 10ft. length supplied).
Part Codes	AC model: SPZ-1ALG-M111 DC model: SPZ-1ALG-L111



Simplifying Complexity. Delivering Safety.



### General Arrangement Drawings

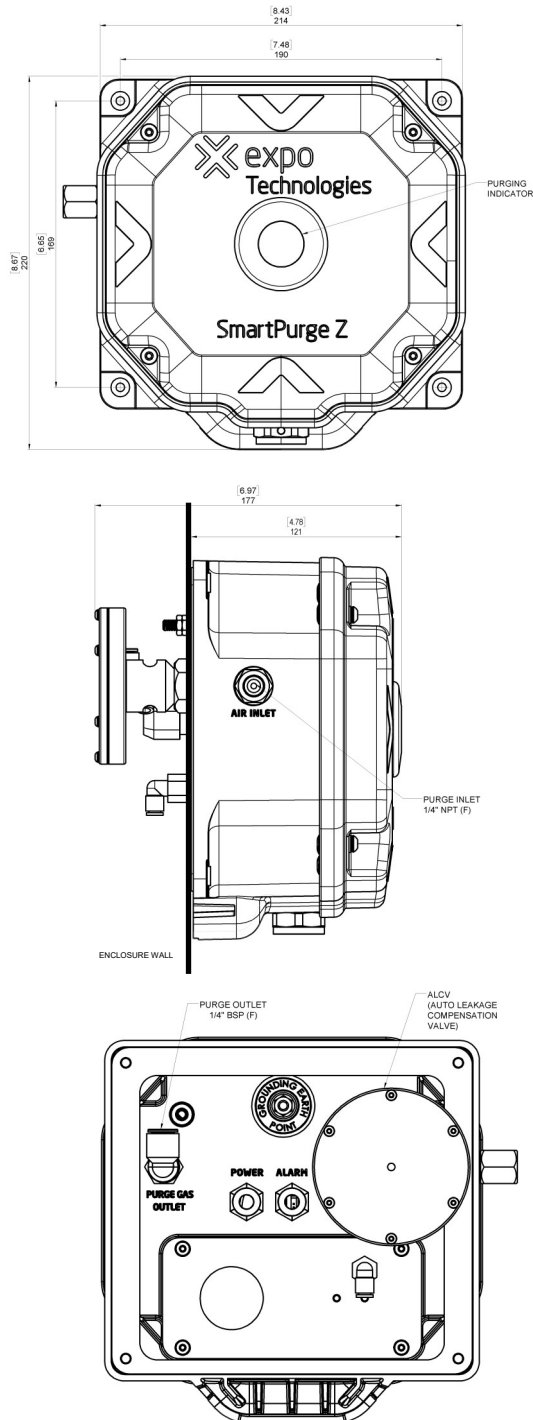

### Hazardous Area Certification

**ATEX:**  
 II 3 (3) G Ex ec ic nC [pzc Gc] IIC T5 Gc  
 Tamb -20 °C to +58°C

**IECEX:**  
 Ex ec ic nC [pzc Gc] IIC T5 Gc  
 Tamb -20 °C to +58°C

**UKEX:**  
 II 3 (3) G Ex ec ic nC [pzc Gc] IIC T5 Gc  
 Tamb -20 °C to +58°C

SPZ Datasheet EN ATEX\_IECEX\_UKEX  
 MKTG 19082024

Expo Technologies Ltd.  
 Unit 2, The Summit,  
 Hanworth Road,  
 Sunbury on Thames,  
 TW16 5DB, UK.  
 T: +44 (0) 208 398 8011  
 E: sales@expoworldwide.com

Expo Technologies Inc.  
 9140 Ravenna Road, Unit #3,  
 Twinsburg,  
 OH 44087,  
 USA  
 T: +1 (440) 247 5314  
 E: sales.na@expoworldwide.com

Qingdao Expo M&E Technologies  
 Co. Ltd.  
 329 Huashan Er Lu,  
 Jimo City, Qingdao,  
 266200 China  
 T: +86 532 8906 9858  
 E: qingdao@expoworldwide.com

Expo Technologies Ltd.  
 Johannstraße 37  
 3rd Floor  
 40476 Düsseldorf,  
 Germany  
 T: +49 (0) 211 5408 5105  
 E: sales@expoworldwide.com

